

# Crow

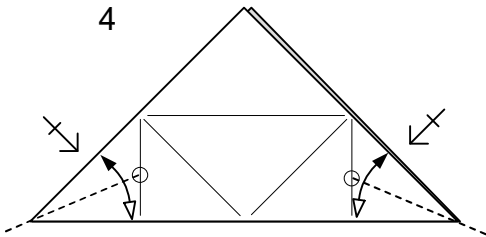

Make 4 valley creases -  
only crease up to the circled reference

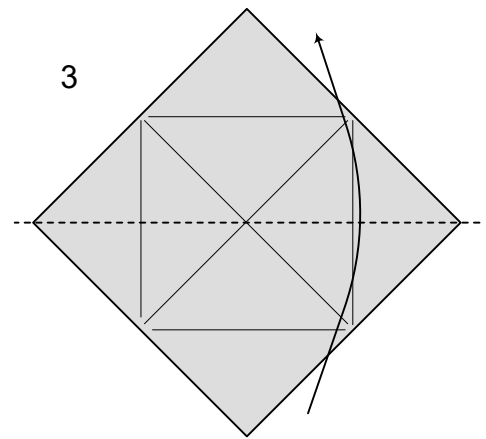
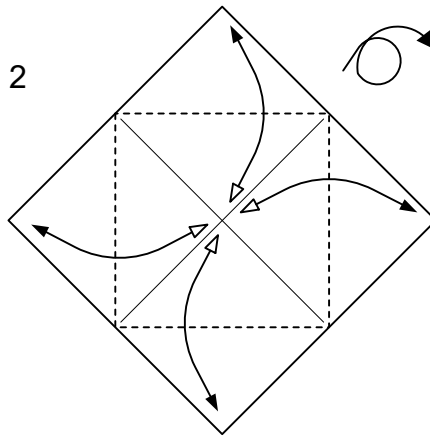
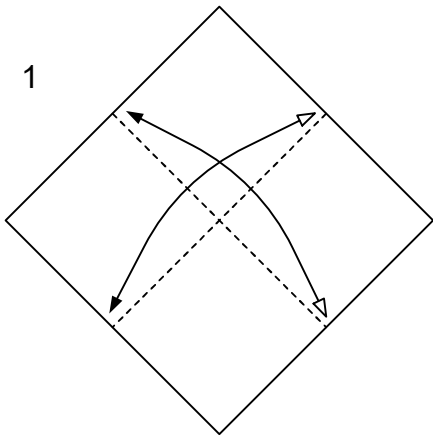
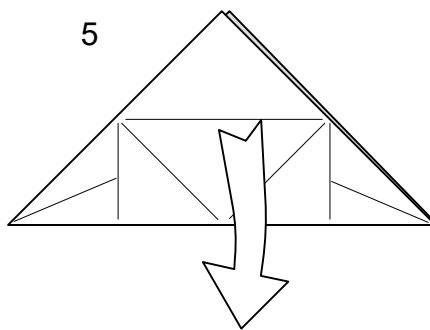

Unfold

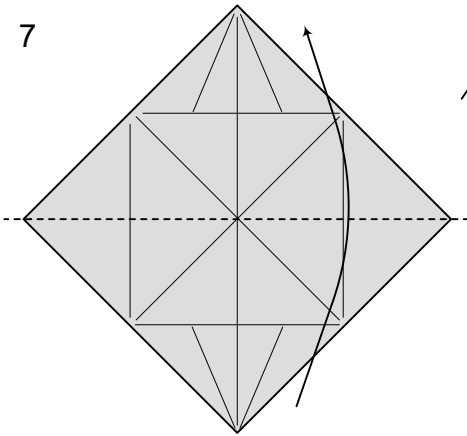
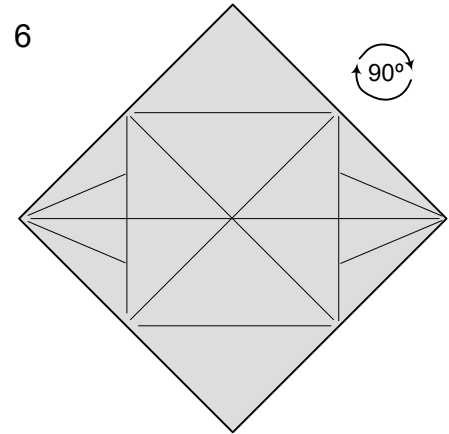

Repeat steps 3 to 5

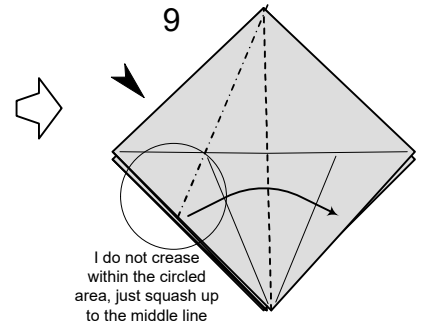
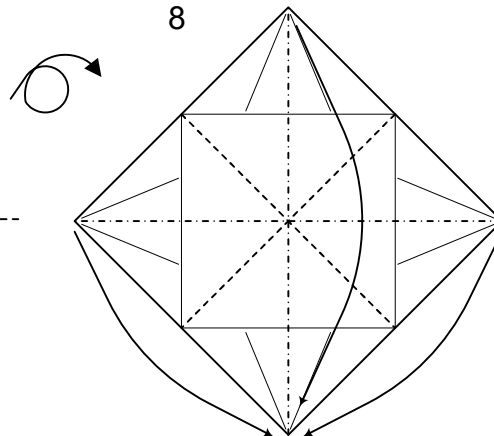

I do not crease  
within the circled  
area, just squash up  
to the middle line

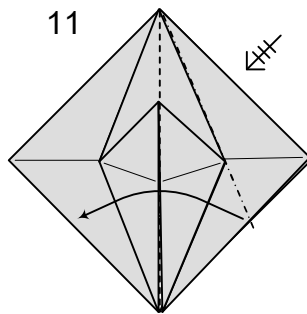
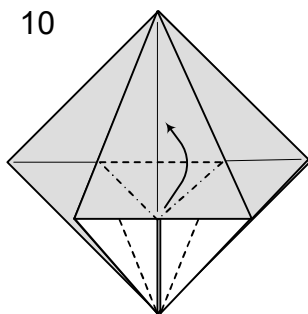

Repeat steps 9 and 10  
on the other 3 sides

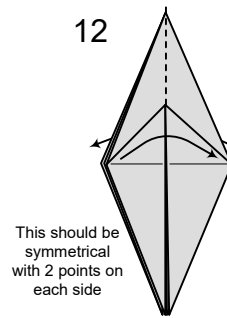

This should be  
symmetrical  
with 2 points on  
each side

Keeping the model  
symmetrical, fold one layer  
across front and back

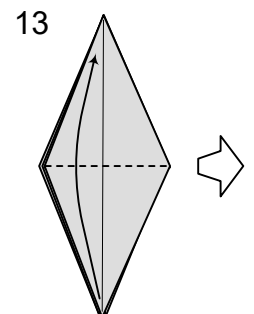

Fold 1 layer to the top

# Crow

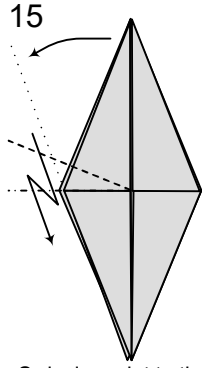
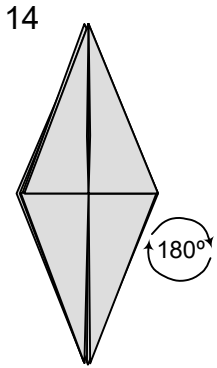

Swivel a point to the left so that it continues the line of the bottom edge

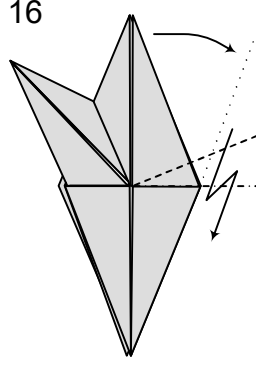

Swivel the other point to the right

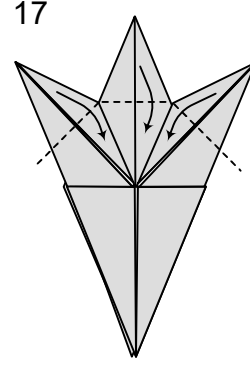

Valley fold the three points to the centre

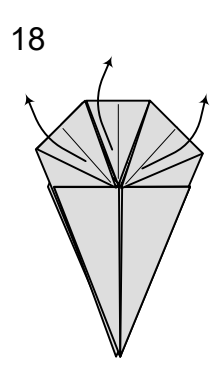

Unfold

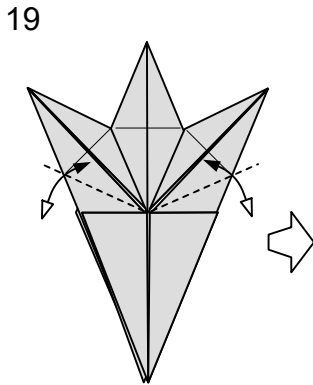

Crease the top layer only - this makes the next step a little easier

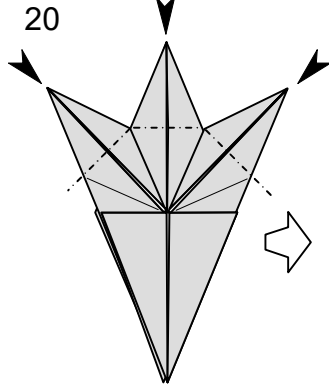

Sink the points inside

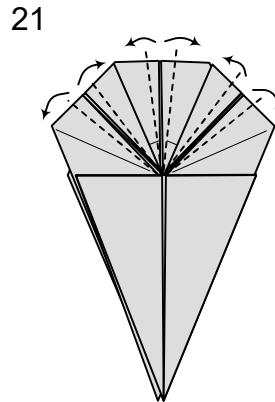

Make small valley fold to form feathers

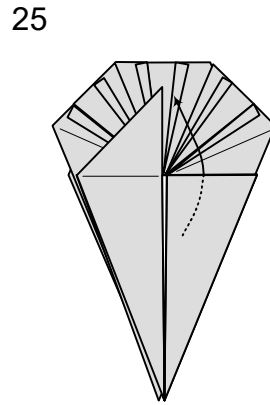
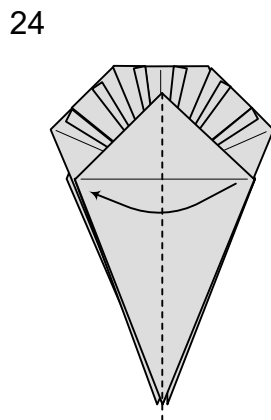
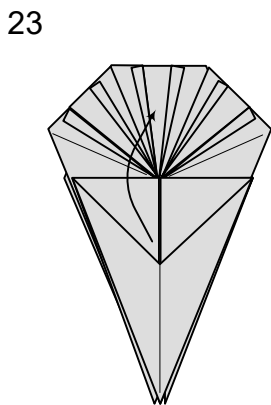
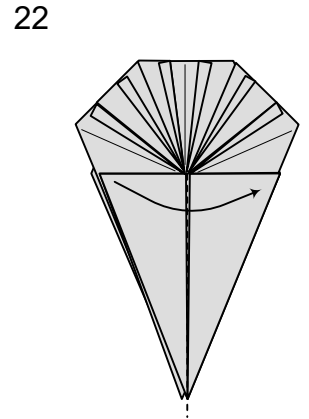

Repeat 22-24 to bring up the other point

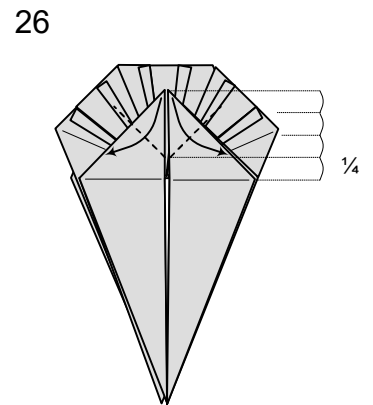

This does not have to be exactly one quarter

# Crow

26

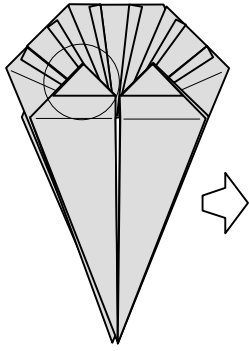

To make the eye, we are going to view the circled point in isolation

27

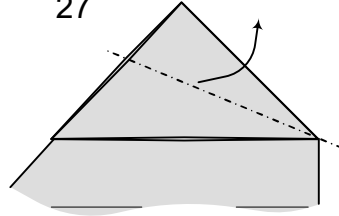

Squash fold

28

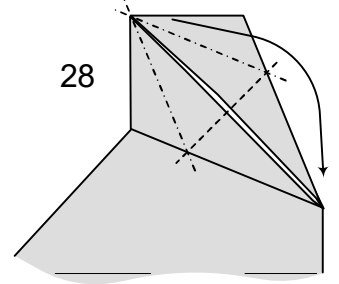

Petal fold

29

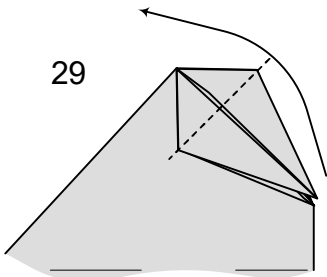

30

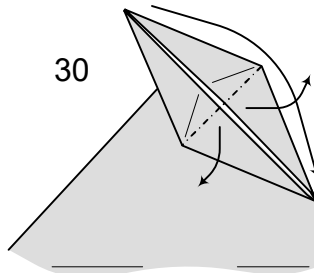

Open up the single layers and squash fold the point down

31

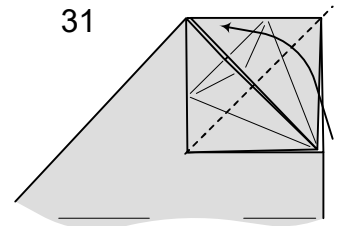

32

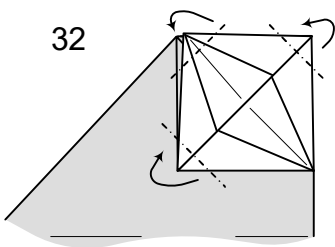

33

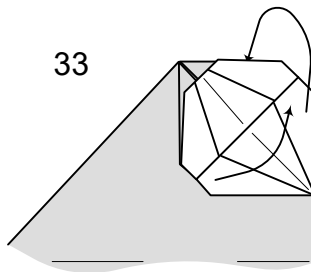

34

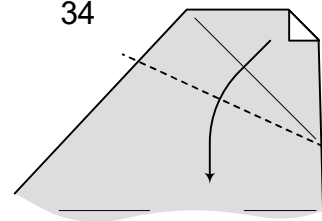

35

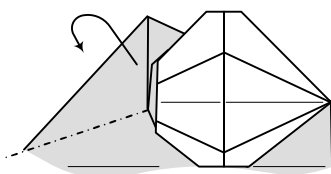

36

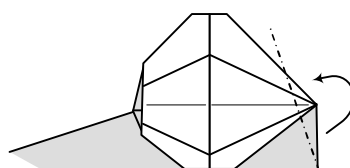

37

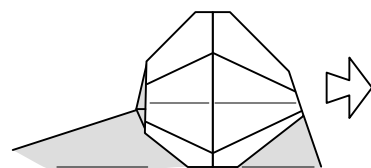

# Crow

38

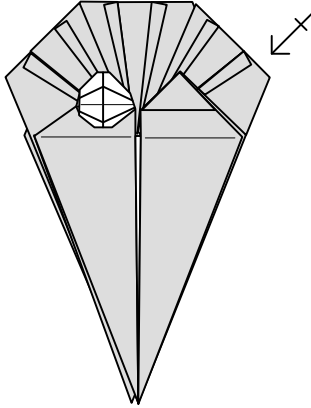

Repeat steps 27-37 on the other point

39

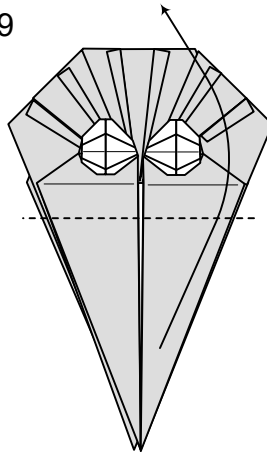

40

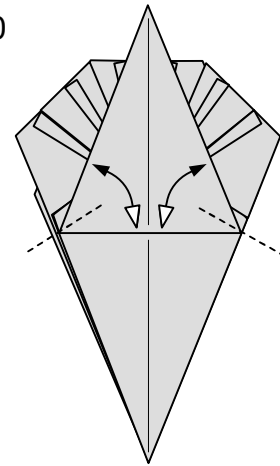

Make 2 sharp creases about half way to the centre line

41

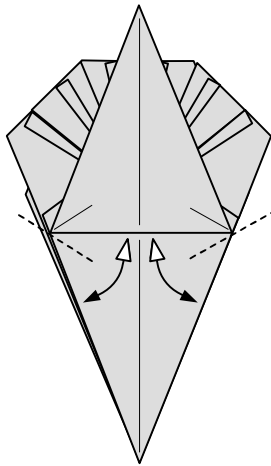

42

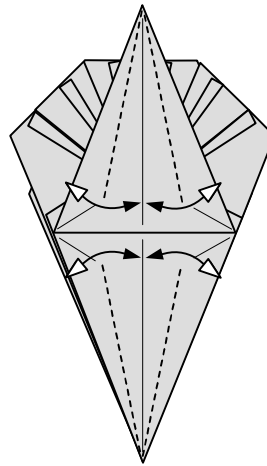

These creases should be made lightly, just bending the paper

43

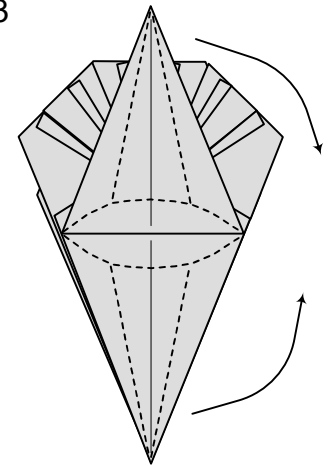

Make the beak 3-dimensional, gently curving the head back

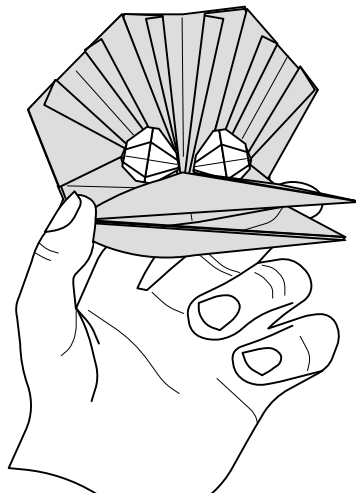

Gently squeeze the sides to make the beak open and close